Aspects of mathematical modeling & simulation of metal casting processes

Principle ideas and examples from foundry practise

by Joachim Linn (ITWM Kaiserslautern)

EMS school on industrial mathematics

Mathematical research & conference center

Bedlewo, October 11-18 (2010)

Overview

- **Fraunhofer ITWM** (some brief infos about ...)
- **Iron casting in sand molds**
- **Physical & mathematical modeling of the metal casting process**
- **Summary & Outlook: Relation to a problem in sausage fabrication**

The Fraunhofer-Group

59 institutes in Germany

- ~ 17 000 employees
- ~ 1.6 billion€ budget

Kaiserslautern:

- ITWM (industrial mathematics)
- IESE (software engineering)

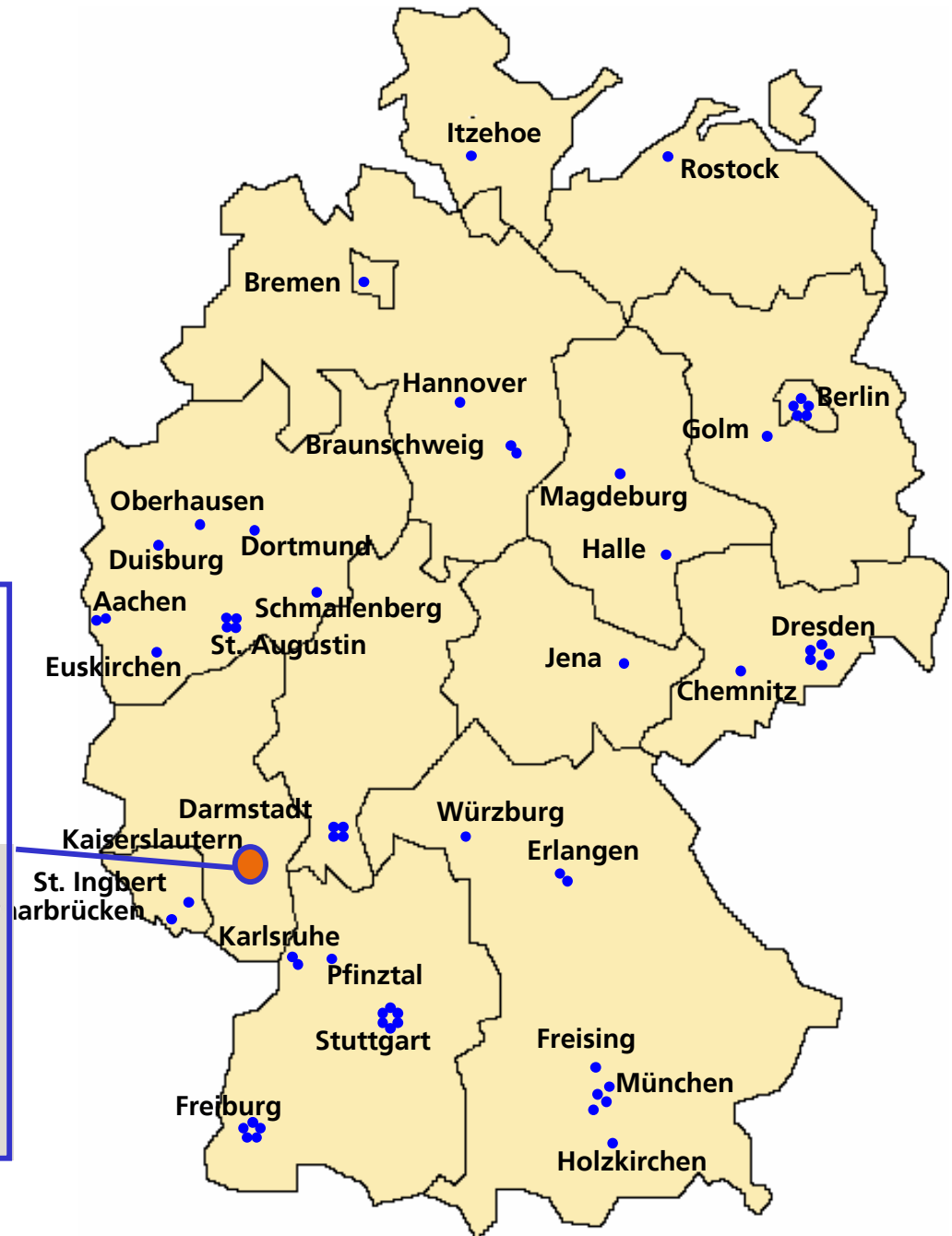
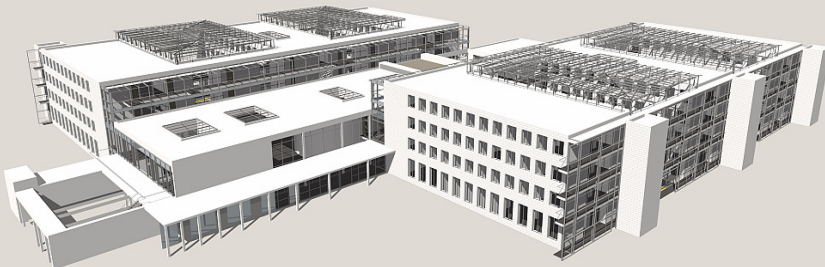

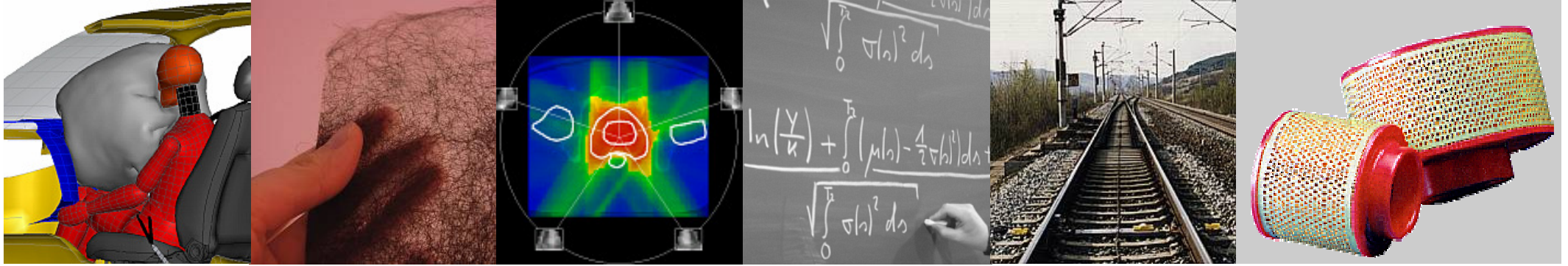

- Fraunhofer-Institute for Industrial Mathematics (ITWM)
- Activities / departments:
 - Structural mechanics / dynamics & durability
 - Fluid dynamics, flow in complex structures
 - Image processing
 - Optimization
 - Adaptive systems
 - Financial mathematics
 - High Performance Computing
- 195 employees
- budget 2009: 15,2 Mio. Euro

Overview

- **Fraunhofer ITWM** (some brief infos about ...)
- **Iron casting in sand molds**
- Physical & mathematical modeling of the metal casting process
- Summary & Outlook: Relation to a problem in sausage fabrication

Typical elements of a metal casting process

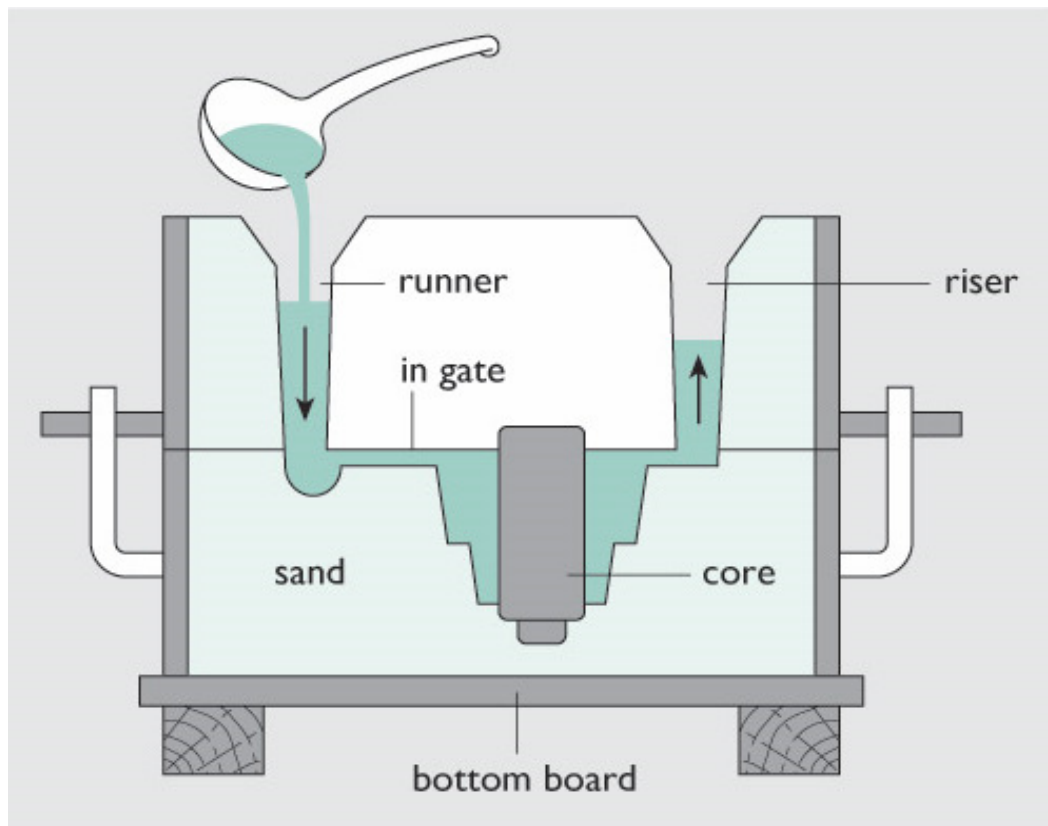

■ The mold filling phase:

- Pouring liquid metal into the mold

■ The solidification phase:

- Metal within the filled mold »freezes«

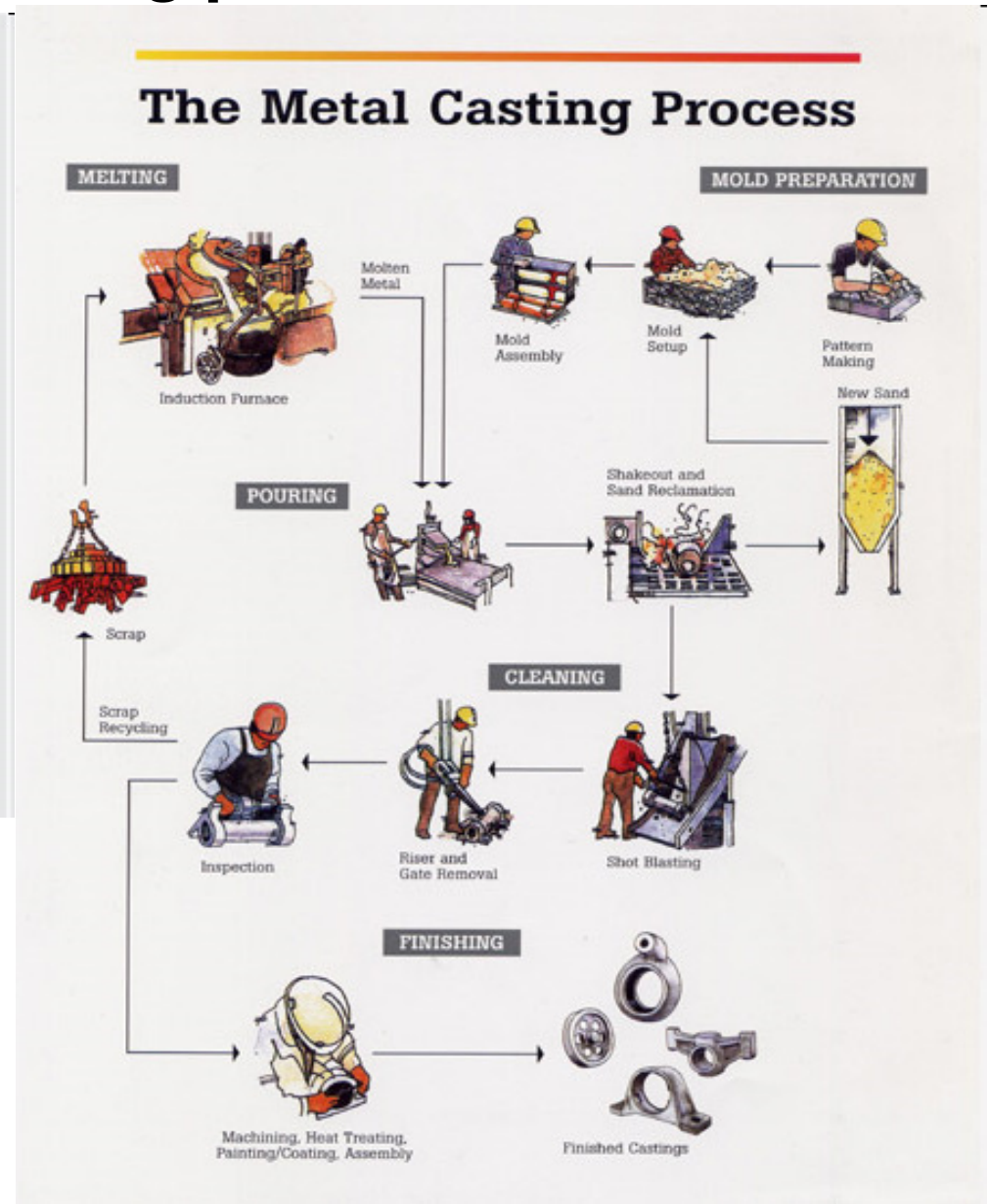

Solidification simulation for iron casting in sand molds

- Casting simulation at ITWM with *MAGMASOFT* : since 1996
- Optimization of the casting process in the computer („*virtual casting*“)
- Prediction of porosities and local microstructure in the casting

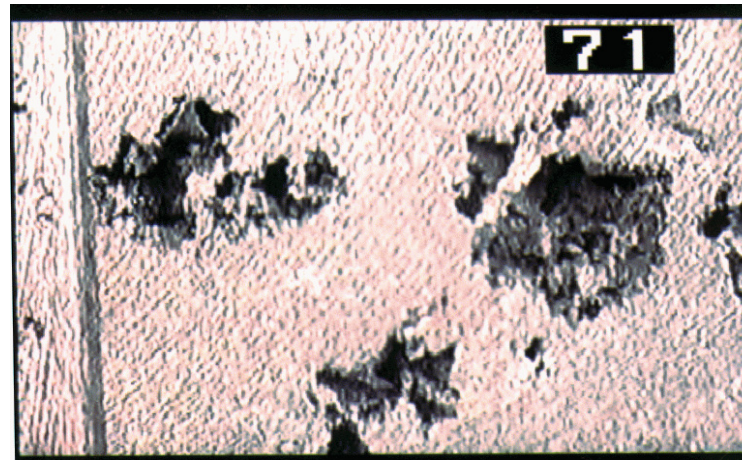

Porosities
("Lunker")

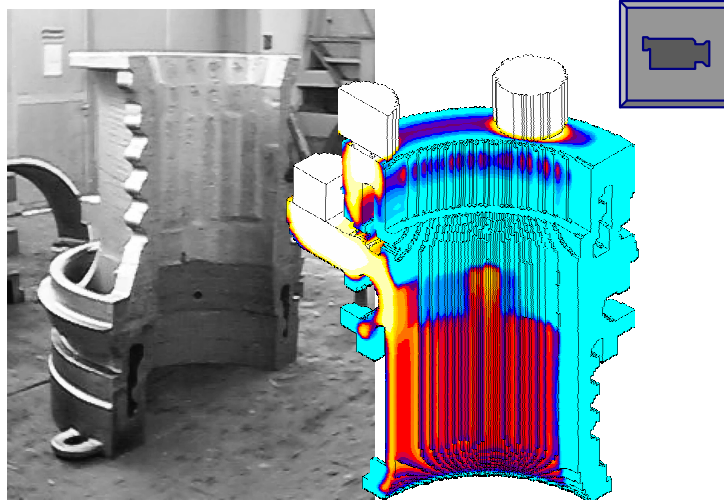

example: by *HegerGuss* (1997)

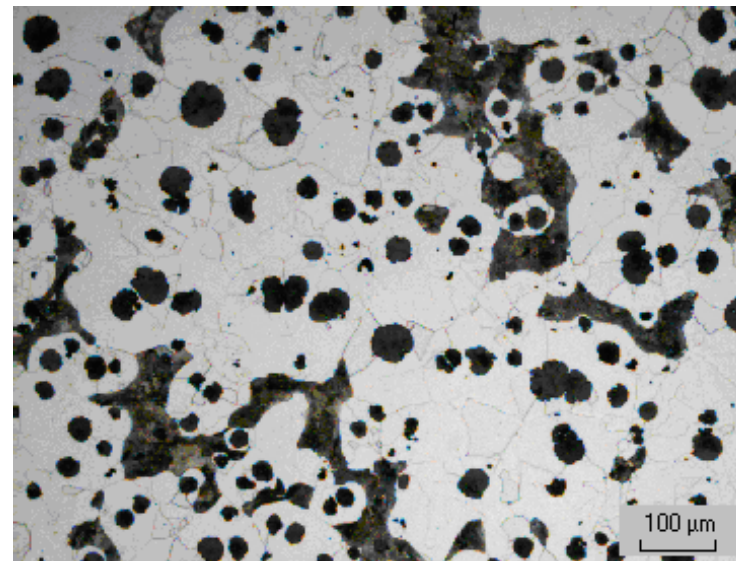

Microstructure:
→ *graphite nodules*
(number & size)
→ *ferrite & pearlite*
distribution

Fe +

% C	% Si	% Mn	% P	% S	% Mg	% Cu	% Ni	% Cr	ppm Pb	ppm As	ppm Ce	ppm Sb	ppm Bi	ppm B
3,54	2,37	0,34	0,02	0,013	0,014	0,49	0,031	0,023	<3	19	30	5	32	<5

Casting process simulation in foundry practice

■ Detailed simulation of the mold filling process

- *very high resolution in space & time*
- virtual try-out of new & improved gating systems
- detailed visualization of the turbulent initial phase

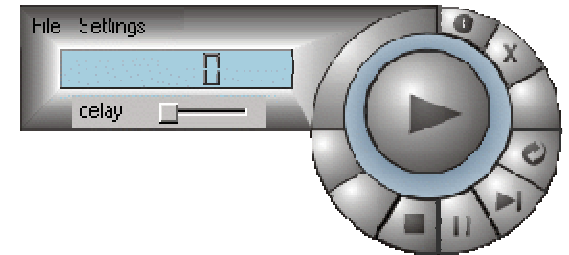

■ Time resolved analysis of the solidification process

- capturing of the *moving melt front* and its shrinkage to the »*hot spots*« (= last solidifying areas)
- virtual try-out of different »cooling strategies« to influence the location of the »hot spots« in the casting

■ Detection of *localized porosities* in the solidified casting

- **Stereo visualisation:** helpful for navigation in *complex geometries*



- Visualization of simulated porosities in a large motor block with **PV4D magmaVR**
 - simulation model: ~ 120 Mio. control vol.
 - ... about 14 Mio. metal cell voxels



Overview

- Fraunhofer ITWM (some brief infos about ...)
- Iron casting in sand molds
- **Physical & mathematical modeling of the metal casting process**
- Summary & Outlook: Relation to a problem in sausage fabrication

Modeling the phases of the sand casting processes

■ Simulation of the mold filling phase:

- *Gravity driven free surface flow* of the liquid metal (incompressible Newtonian fluid) into the empty cavity of the sand mold
- *Heat transport* (→ convection & diffusion) within the melt and into the sand mold
- *Species Transport* (& reaction kinetics) of the alloying elements ($Fe + C + Si + \dots$)

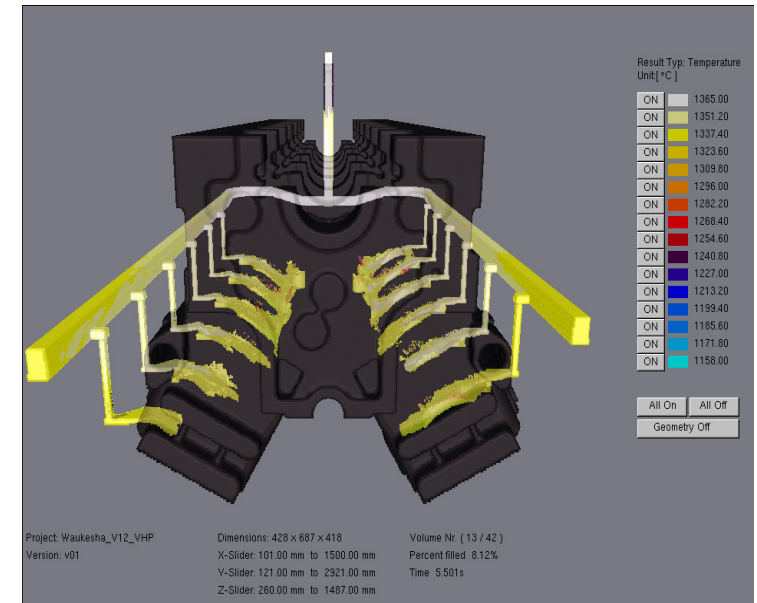

■ Simulation of the solidification phase:

- *Heat transport* (mainly diffusion) from the melt into the sand mold
- Liquid to solid *phase transition* with *release of latent heat*
- Thermodynamic *phase reactions*

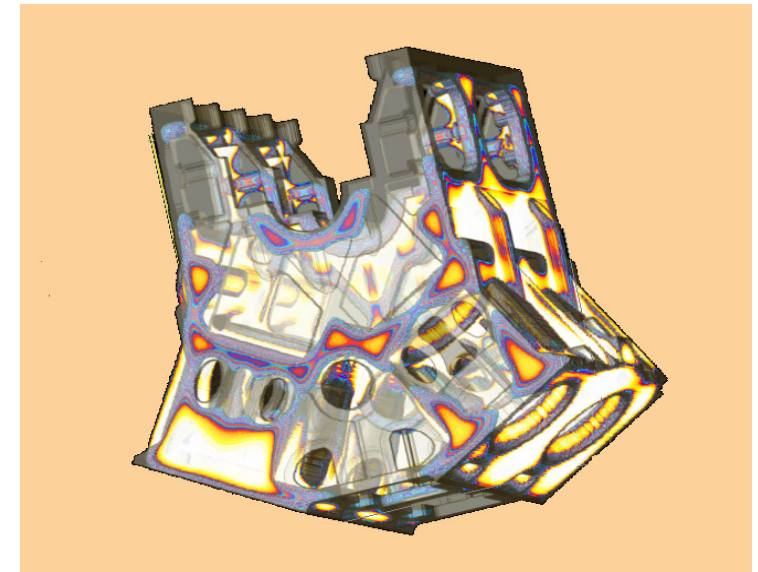

■ ... & build up of **residual stresses** ...

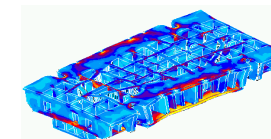

Physical & mathematical modeling for casting simulation

■ Basic balance equations:

- conservation of *mass*

$$\frac{D\rho}{Dt} = 0 \Leftrightarrow \nabla \cdot \mathbf{v} = 0$$

- conservation of *momentum*

$$\rho \frac{D\mathbf{v}}{Dt} = -\nabla p + \eta \Delta \mathbf{v} + \rho \mathbf{b}$$

- conservation of *energy*

$$\rho c_p \frac{DT}{Dt} = \nabla \cdot (\lambda \nabla T) + \eta \dot{\gamma}^2 + \dot{q}_{LH}$$

■ Additional transport equations:

- Movement of the *free surface*
- Transport & reaction kinetics of species (alloying elements)

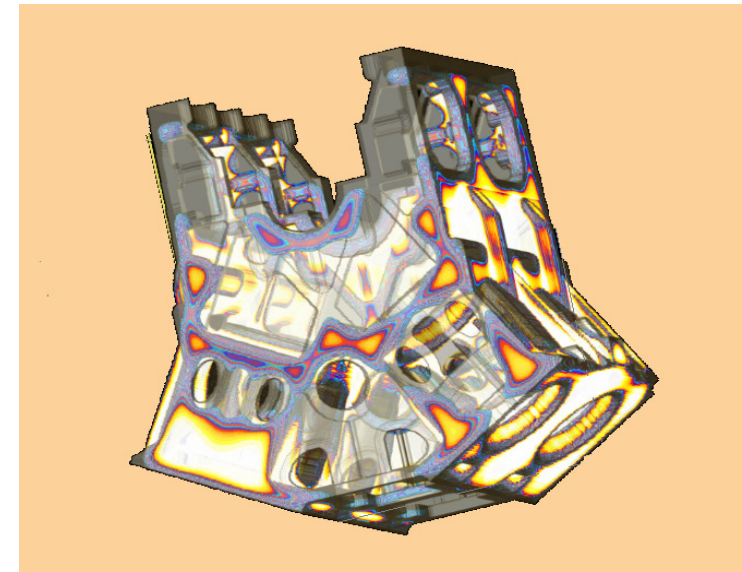
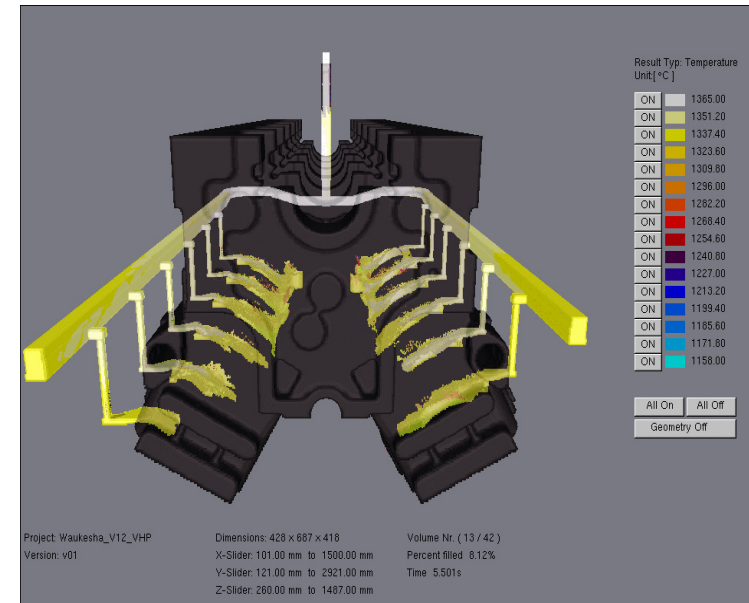

Local equations of mass & momentum conservation

■ **Local conservation of mass:** $\frac{\partial \rho}{\partial t} + \nabla \cdot (\rho \mathbf{v}) = \frac{D\rho}{Dt} + \rho(\nabla \cdot \mathbf{v}) = 0$

■ Mass density ρ of the fluid

■ Incompressibility condition on the flow velocity \mathbf{v} :

$$\frac{D\rho}{Dt} = 0 \Leftrightarrow \nabla \cdot \mathbf{v} = 0$$

■ **Local conservation of momentum:**

■ body force \mathbf{b} , stress tensor \mathbf{T}

■ pressure p and viscous stress \mathbf{T}' :

$$\rho \frac{D\mathbf{v}}{Dt} = \nabla \cdot \mathbf{T} + \rho \mathbf{b}$$

$$p = -\frac{1}{3} \text{Sp}(\mathbf{T}), \mathbf{T}' = \mathbf{T} + p \mathbf{I}$$

$$\Rightarrow \nabla \cdot \mathbf{T} = -\nabla p + \nabla \cdot \mathbf{T}'$$

■ Viscous stress of a *Newtonian fluid*:
→ viscosity parameters $\eta, \zeta > 0$

$$\mathbf{T}' = \eta(\nabla \mathbf{v} + \nabla \mathbf{v}^T) + (\zeta - \frac{2}{3}\eta)(\nabla \cdot \mathbf{v}) \mathbf{I}$$

■ incompressible Newtonian fluid:

$$\nabla \cdot \mathbf{T} = -\nabla p + \eta \Delta \mathbf{v}$$

■ **Navier-Stokes equations:**
(incompressible Newtonian fluid)

$$\rho \frac{D\mathbf{v}}{Dt} = -\nabla p + \eta \Delta \mathbf{v} + \rho \mathbf{b}$$

Modeling of Injection molding for thermoplastic materials

■ Non-Newtonian fluids:

- Non-Newtonian flow properties: viscous stress depends *nonlinearly* on the symmetric velocity gradient

$$\mathbf{T}' = \mathbf{C}[\mathbf{G}], \quad \mathbf{G} = \frac{1}{2}(\nabla \mathbf{v} + \nabla \mathbf{v}^T)$$

■ Generalized newtonian fluid:

- scalar *viscosity* η depends on local *pressure* and *shear rate*

$$\eta(p, \dot{\gamma}), \quad \dot{\gamma} = \sqrt{\mathbf{G} : \mathbf{G}}$$

■ Stokes flow (slow & very viscous):

- *inertial effects* are (negligibly) *small*

$$\rho \frac{D\mathbf{v}}{Dt} = \rho \left(\frac{\partial \mathbf{v}}{\partial t} + \mathbf{v} \cdot \nabla \mathbf{v} \right) \rightarrow \rho \frac{\partial \mathbf{v}}{\partial t} (\rightarrow 0)$$

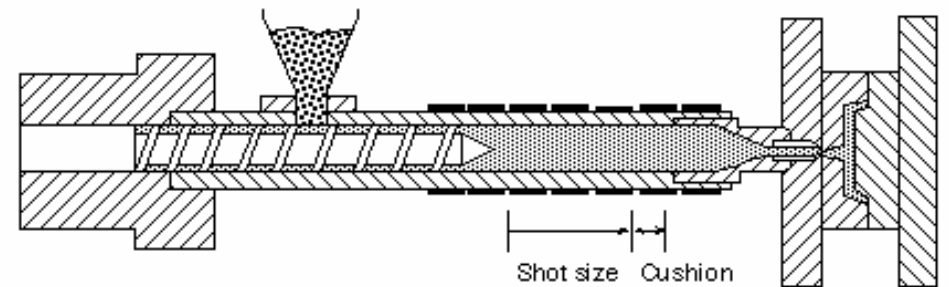

Motion of the free surface

■ Front tracking of the liquid / gas interface

- »*Volume of fluid*« (VOF) function: $\Phi(\mathbf{x})$
- domain filled by liquid: $\Phi(\mathbf{x}) = 1$
- domain filled by gas: $\Phi(\mathbf{x}) = 0$
- discontinuity = »sharp« interface location
- approximate interface location: $0 < \Phi(\mathbf{x}) < 1$

0	0	0	0	0	0	0	0
0	0.10	0.58	0.86	0.85	0.52	0.09	0
0	0.76	1	1	1	1	0.61	0
0	0.78	1	1	1	1	0.60	0
0	0.09	0.57	0.84	0.83	0.51	0.08	0
0	0	0	0	0	0	0	0

■ Convective transport of the VOF function

$$\frac{\partial \Phi}{\partial t} + \nabla \cdot (\Phi \mathbf{v}) = \frac{D\Phi}{Dt} + \Phi (\nabla \cdot \mathbf{v}) = 0$$

- transport of the liquid/gas interface with the flow

■ similar / alternative approach: »*Levelset method*«

Energy balance

■ conservation of internal energy for incompressible fluids:

- convective **heat transport**: enthalpy
- heat source: **viscous dissipation**
(→ special case: Newtonian, incompressible)
- Fourier's law of **heat conduction**

■ local release of latent heat:

- material function $f_s(T)$: »**fraction solid**«
- solidification interval: $T_{sol} \leq T \leq T_{liq}$
- amount of **latent heat** released at temperature T: $q_{LH}(T) \sim Q_{LH} \cdot f_s(T)$
- heat source: **rate** of latent heat release

$$\dot{q}_{LH} = \rho Q_{LH} \frac{df_s}{dT} \frac{\partial T}{\partial t}$$

$$\rho c_p \frac{DT}{Dt} = \mathbf{T} : \nabla \mathbf{v} - \nabla \cdot \mathbf{q}$$

$$h = e + \frac{p}{\rho} = \int^T c_p dT \Rightarrow \frac{Dh}{Dt} = c_p(T) \frac{DT}{Dt}$$

$$\mathbf{T} : \nabla \mathbf{v} \rightarrow \eta \dot{\gamma}^2, \quad \dot{\gamma} = \sqrt{\mathbf{G} : \mathbf{G}}$$

$$\mathbf{q} = -\lambda \nabla T$$

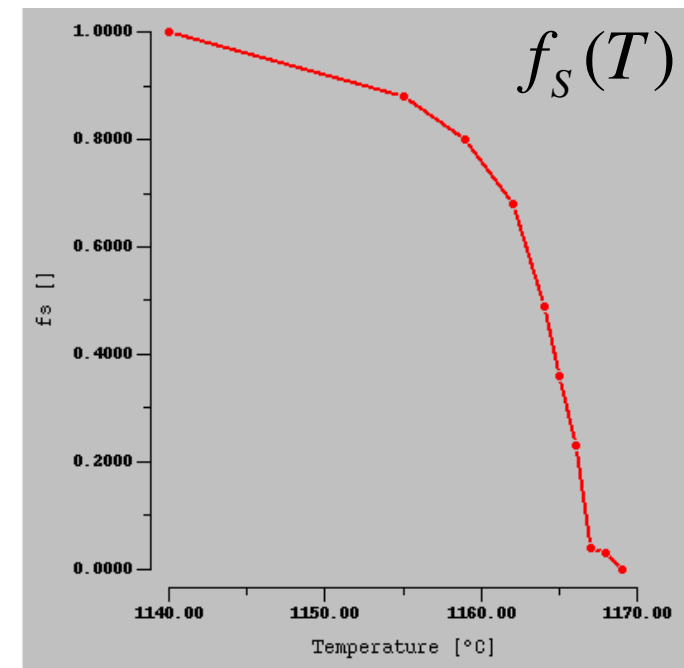

Effective heat capacity & release of latent heat (GJS 400)

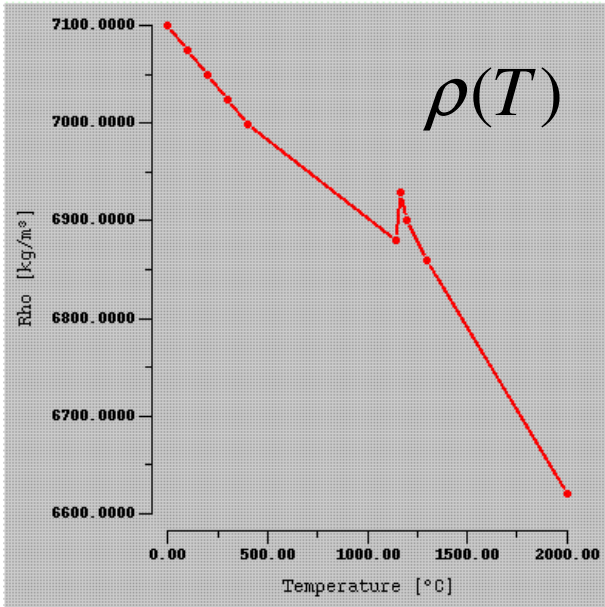
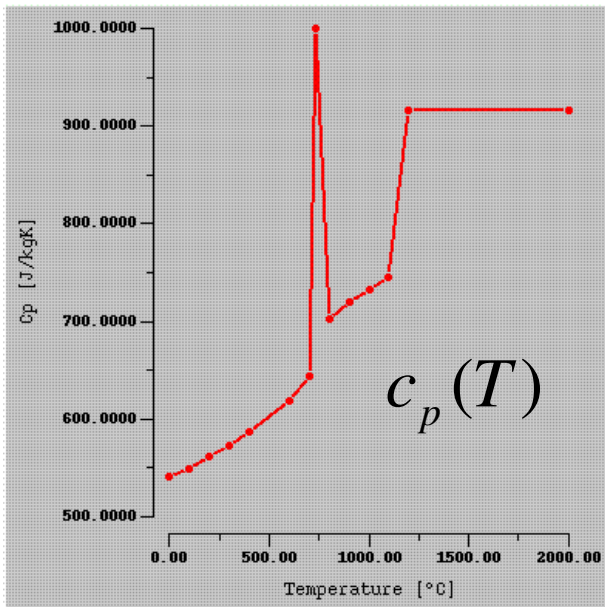

$$C_{eff}(T) = c_p(T) - Q_{LH} \frac{df_s}{dT}(T)$$

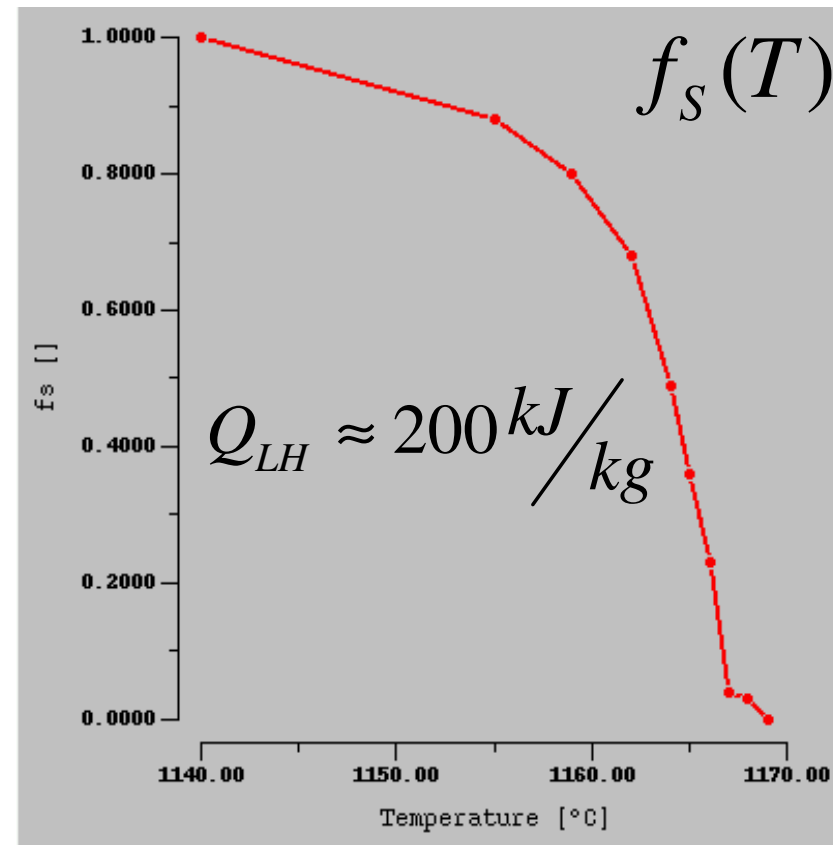

Effective heat capacity & release of latent heat

$$\rho C_{eff}(T) = \rho \left[c_p(T) - Q_{LH} \frac{df_s}{dT}(T) \right]$$

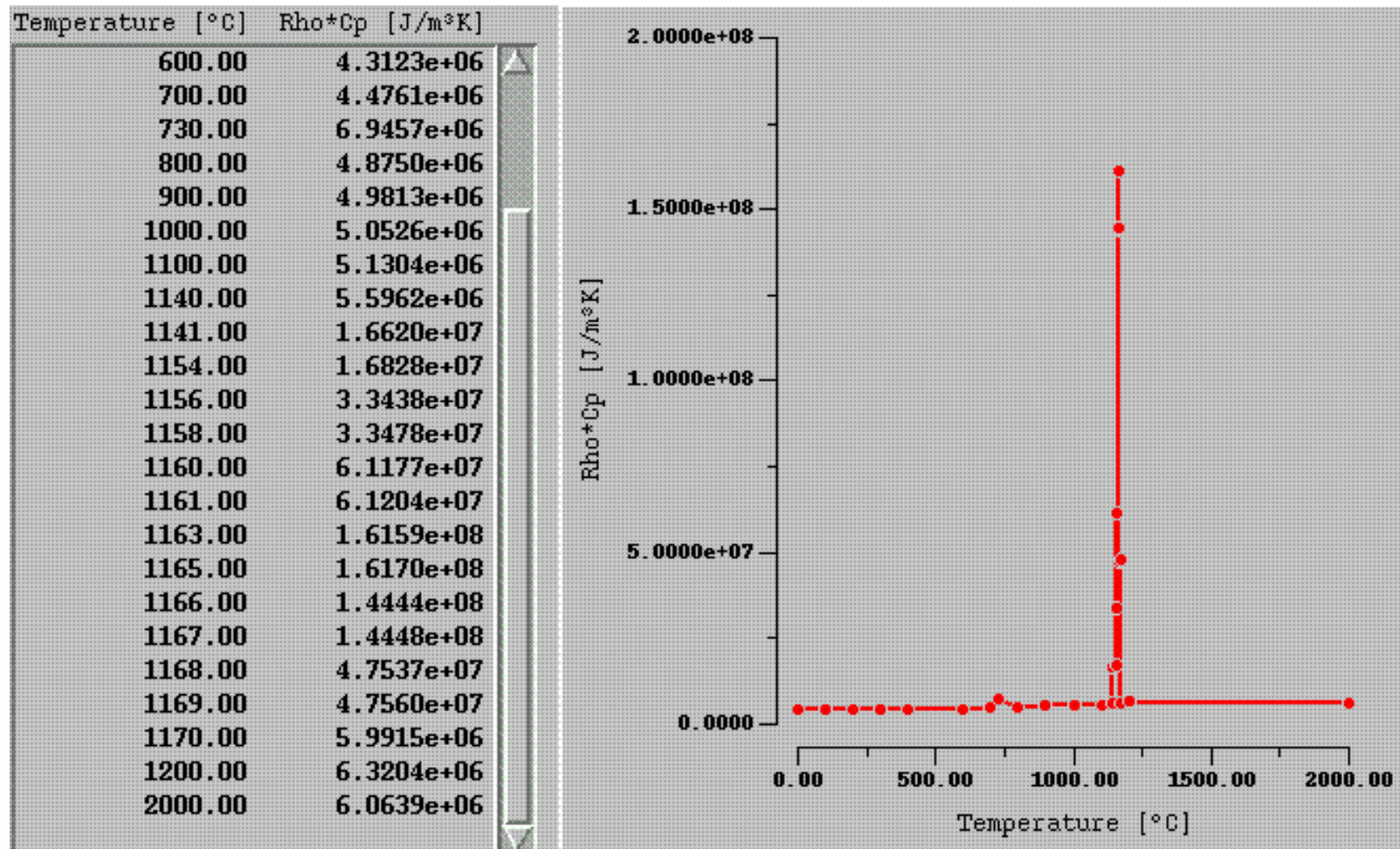

Solidification simulation with simplified heat conduction

■ Simplifications for metal castings

- »wall thickness« not to large
⇒ heat convection may be neglected !
- latent heat release = dominant heat source
⇒ viscous dissipation is negligible !

■ Effective thermal conductivity

- increased values at higher temperatures account for local convective effects

■ Heat equation with effective heat capacity

$$\rho C_{eff}(T) \frac{\partial T}{\partial t} = \nabla \cdot [\lambda_{eff}(T) \nabla T]$$

$$C_{eff}(T) = c_p(T) - Q_{LH} \frac{df_s}{dT}$$

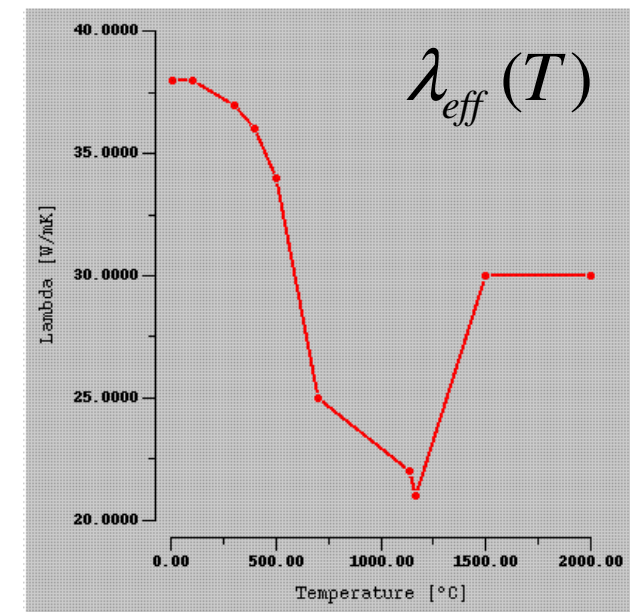
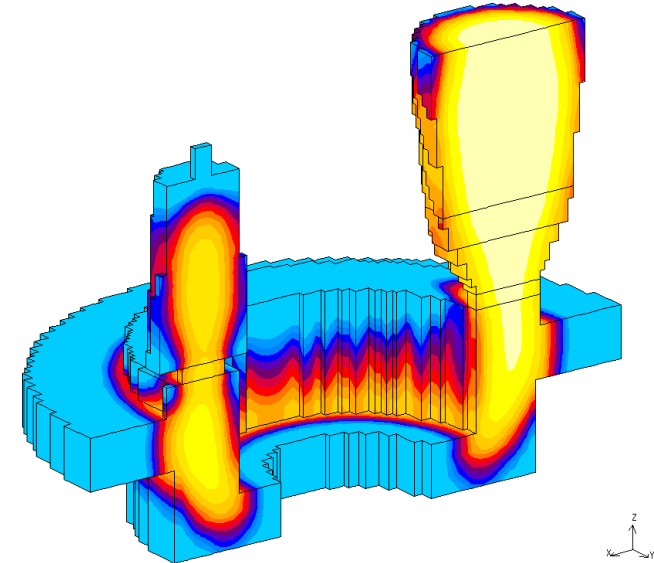

More modeling topics in casting process simulation

■ Heat transport in the mold and into the environment

- Material properties of resin bound molding sands

■ Boundary conditions ...

- ... between the mold (solid) and the melt (fluid),
- ... at the free interface between melt and air / pressure & surface tension,
- ... between mold and environment: cooling by convection & radiation.

■ Initial conditions for mold filling

■ Microstructure formation during solidification (→ Thermodynamic phase kinetics)

■ Porosity formation in the solidifying melt ...

- ... due to uncompensated shrinkage in the »hot spots«
- ... due to *nucleation & growth of gas bubbles*

Summary

- **Manufacturing process: iron casting into sand molds**
 - ... foundries do »virtual casting« to improve of the real process
 - ... some examples of simulation practise in foundries
- **Physical & mathematical modeling of iron casting into sand molds**
 - ... basic conservation equations of mass, momentum & energy
 - ... some general modeling aspects: linear (Newtonian) vs. nonlinear fluids, modeling the free interface fluid/gas interface, slow flow
 - Important: modeling heat flow & phase change during solidification

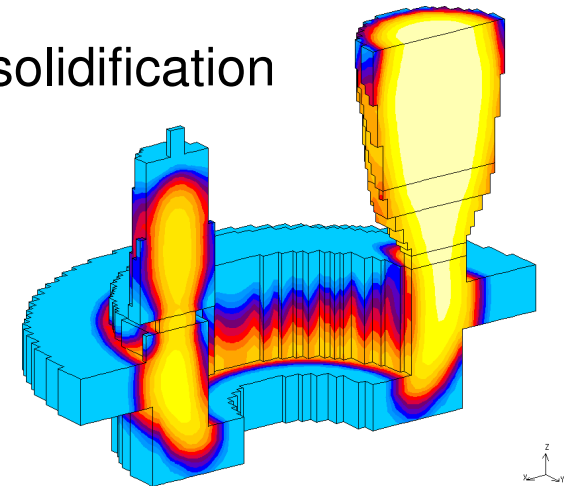

Some useful books

■ Fluid dynamics

- L.D. Landau, E.I. Lifshitz: *Course of Theoretical Physics, Vol.6: Fluid Mechanics* (2nd edition), Butterworth Heinemann (1987)
- G.K. Batchelor: *An Introduction to Fluid Dynamics*, Cambridge University Press (2000)

■ Modeling and simulation of casting processes

- J. Dantzig, M. Rappaz: *Solidification*, EPFL Press / CRC Press Inc. (2009)
- W. Kurz, D.J. Fisher: *Fundamentals of Solidification* (4th rev. edition), Trans Tech Publications (1998)

■ Numerical methods for CFD

- J.H. Ferziger, M. Peric: *Computational Methods for Fluid Dynamics* (3rd edition), Springer (2001)
- S.V. Patankar: *Numerical Heat Transfer and Fluid Flow*, Taylor & Francis (1980)
- R.G. Owens, T.N. Phillips: *Computational Rheology*, World Scientific Publishing (2002)

The problem of air bubbles in sausage fabrication

■ *»During the fabrication of sausages the meat mass is introduced from the vacuum into the sausage cover under pressure. Sometimes air bubbles appear in the sausages. How can this be avoided?«*

■ **Some rough ideas how to model this problem:**

- The fabrication process may have some similarities with injection molding of plastic melts, but into a highly deformable mold (= sausage cover). (?)
- The meat mass is certainly a very viscous fluid, perhaps viscoelastic, and might even show nonlinear flow behaviour. (?)
- The occurrence of air bubbles could be caused by a similar mechanism as the one responsible for the nucleation & growth of gas bubbles in metal casting processes (→ HPDC of aluminum alloys). (?)
- ...

... Everything is (most probably) completely different !

Overview

- **Fraunhofer ITWM** (some brief infos about ...)
- **Iron casting in sand molds**
- **Physical & mathematical modeling of the metal casting process**
- **Summary & Outlook: Relation to a problem in sausage fabrication**
- *Thank you for your attention ! Questions ...?*